



CORTEX

Core monitoring techniques and
experimental validation and demonstration

2nd Cortex Validation Workshop

CORTEX – Measurement campaigns at AKR-2

Alexander Knospe (TUD)

alexander.knospe@tu-dresden.de



This project has received funding from the Euratom research and training programme 2014-2018 under grant agreement No 754316.

Timeline

- Three measurement campaigns to generate data for validation of noise simulation codes
- Requests of modelers had to be taken into account, e.g. small perturbation
- All aspects of the experiments were incrementally improved: perturbation devices, detectors, data acquisition, data analysis

Improvements

Qualification of the
AKR-2 DAQ

1

06.03.-15.03.

2018

2019

2020

Generation of data
close to the core

2

06.07.-15.07.

Uncertainty
estimation

3

22.02.-26.02. (+2 days)

2021



Evolution of detector setup

First campaign

- 3 He-3 proportional counters in the experimental channels
- 3 fission chambers in the reflector region
- 1 ^{10}B -coated ion chamber (γ -compensated) in the reflector region

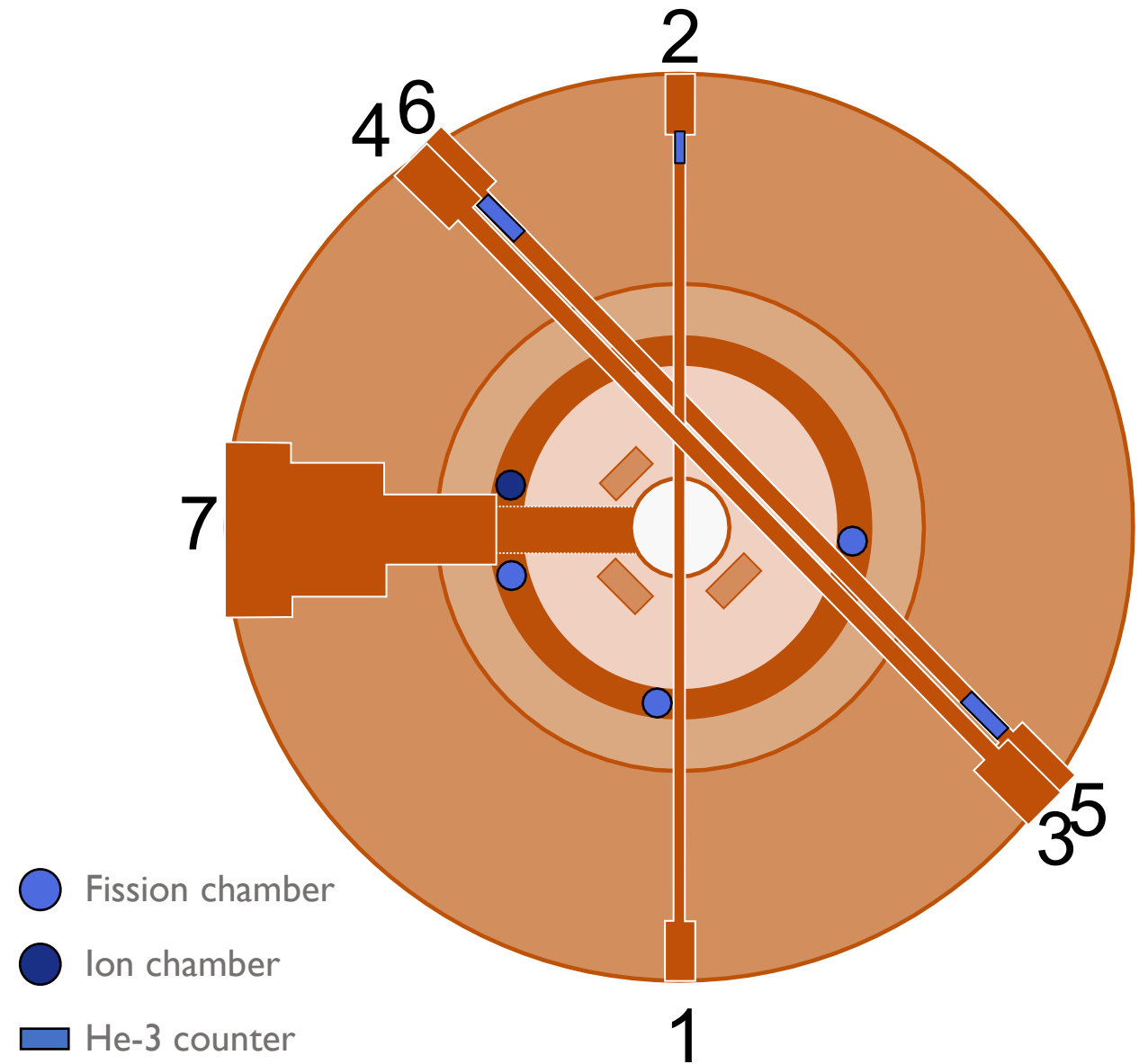

Detector setup of the first campaign



Evolution of detector setup

First campaign

- 3 He-3 proportional counters in the experimental channels
- 3 fission chambers in the reflector region
- 1 ^{10}B -coated ion chamber (γ -compensated) in the reflector region

Second campaign

- 4 He-3 proportional counters in experimental channels
- 2 fission chambers
- 3 miniature scintillators (with help from EPFL)

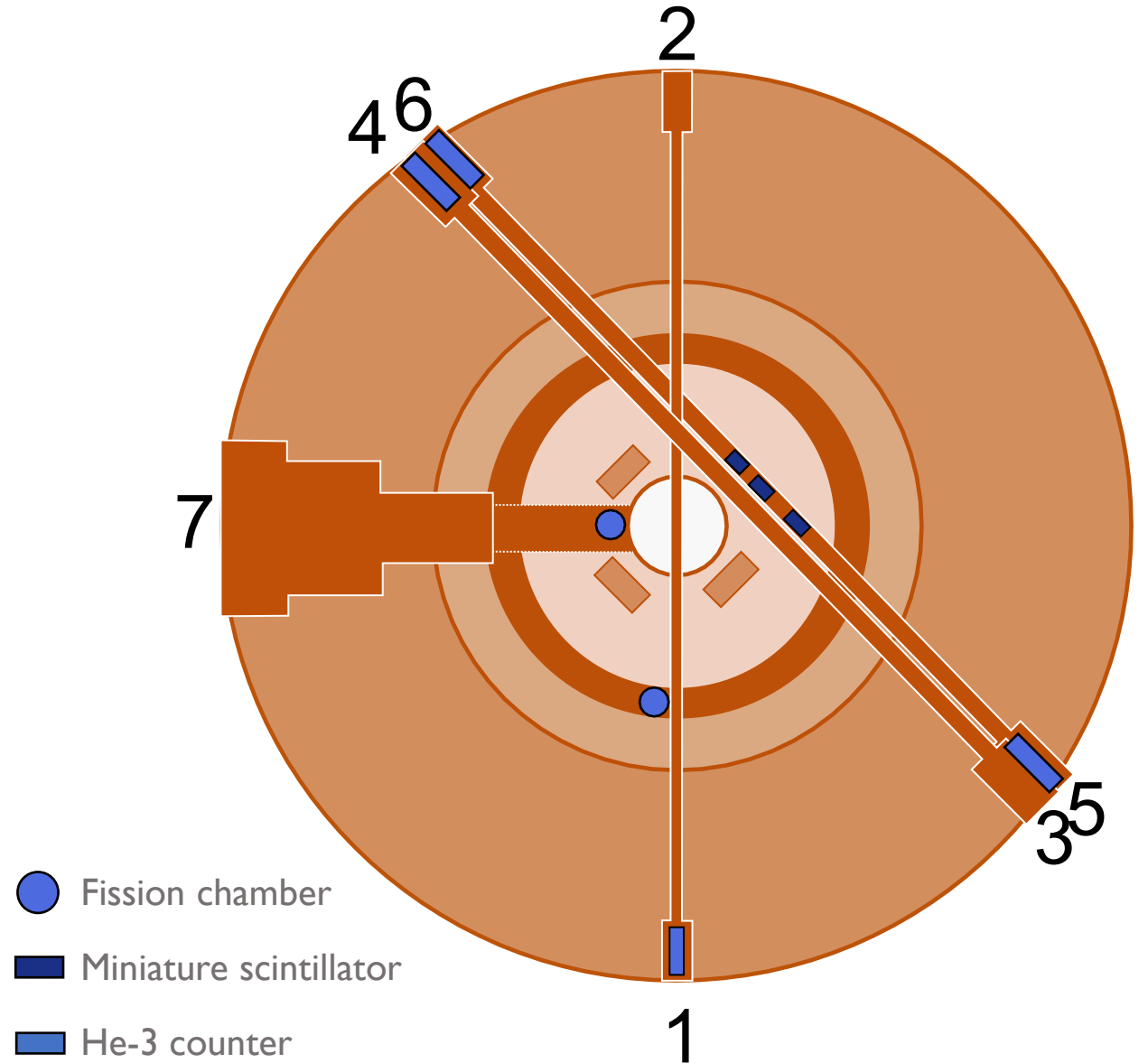

Detector setup of the second campaign



Evolution of detector setup

First campaign

- 3 He-3 proportional counters in the experimental channels
- 3 fission chambers in the reflector region
- 1 ^{10}B -coated ion chamber (γ -compensated) in the reflector region

Second campaign

- 4 He-3 proportional counters in experimental channels
- 2 fission chambers
- 3 miniature scintillators (with help from EPFL)

Third campaign

- 5 He-3 proportional counters in experimental channels
- 2 Fission chambers

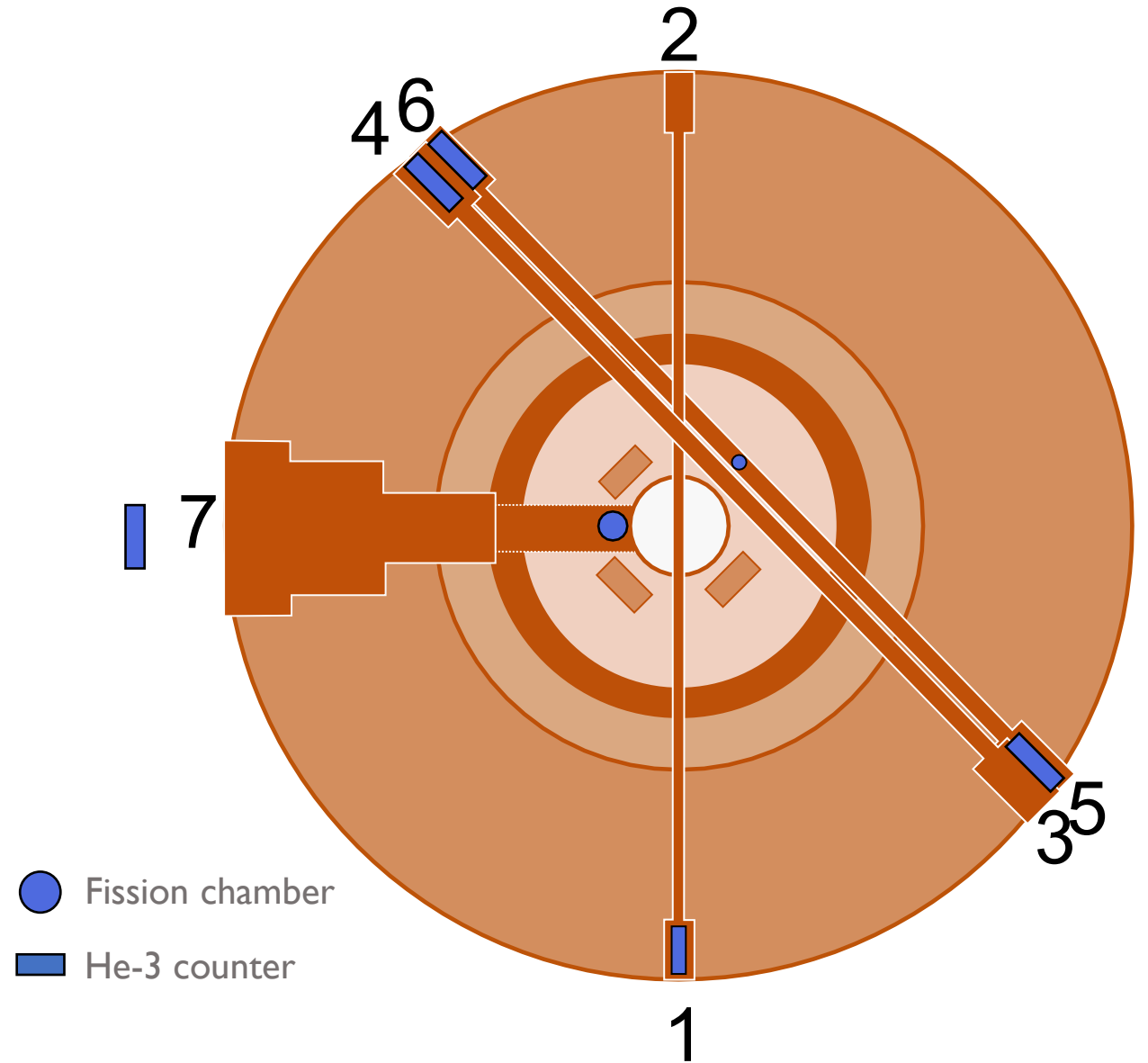

Detector setup of the third campaign

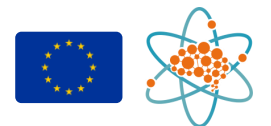

Evolution of noise sources

Vibrating absorber

First campaign

- Drive: pneumatic
- Distance: fixed, 20 cm
- Frequency: 0.08 to 0.71 Hz
- Motion profile: fixed, trapezoidal (jump)
- Unknown accuracy
- from end to end
- pneumatic dropouts

Second/Third campaign

- Drive: linear motor
- Distance: 0 to 31 cm
- Frequency: 0 up to 10 Hz (currently)
- Motion profile: customizable in limits of the system
- Absolutely repeatable motion profile



Pneumatic drive during the first campaign



Linear motor drive during the second and third campaign

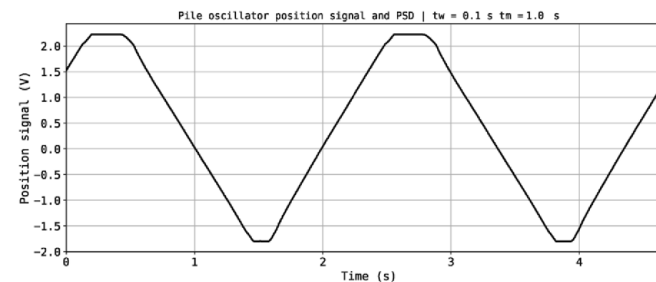

Left: motion profile of VA in the first campaign



Evolution of noise sources

Absorber of variable strength

First campaign/Second campaign

- Drive: stepper motor
- Frequency: 0.1-7 Hz
- inductive/optical position sensor

Third campaign

- Drive: stepper motor
- Frequency: 0.1-15 Hz
- inductive sensor

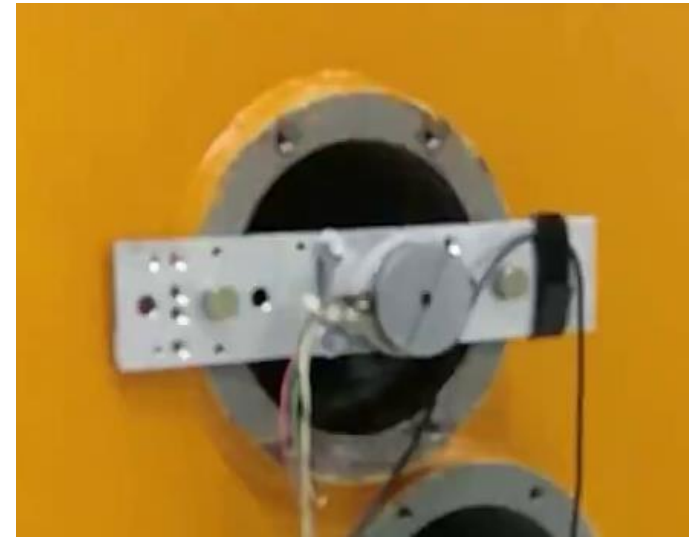

Absorber of variable strength during the first/second campaign



Absorber of variable strength during the third campaign



Measurements

First campaign

- 27 measurements
- VA was driven with moving time t_m and waiting time t_w

Second campaign

- 27 measurements
- VA was driven with sinusoidal profile
- VA was driven in the off-center and center
- Both perturbation devices were also driven at the same time

Third campaign

- 46 measurements
- All measurements were repeated multiple times to confirm uncertainty estimations

First campaign												
AVS												
Frequencies (Hz)	0.2			0.5			1		2			
VA												
Locations, amplitude:	Off center, large											
t_m (s)	0.1	0.4	1	0.1	0.1	0.4	1	2	4	1	0.4	2
t_w (s)	0.6	0.6	0.6	1	2	2	2	2	2	1	0.4	0.4

Second campaign												
AVS												
Frequencies (Hz)	0.1			1			2		4.5			
VA												
Locations, amplitude:	Off center, large			Off center, small				center				
Frequencies (Hz)	0.01		0.1		1		2		4			
Both simultaneously												
Locations, amplitude:	Off center, large											
Frequencies (Hz)	0.1						2					

Third campaign												
AVS												
Frequencies (Hz)	0.1			2			4		10			
VA												
Locations, amplitude:	Off center, large			Off center, small				center				
Frequencies (Hz)	0.1		1		2		10					
Both simultaneously												
Locations, amplitude:	Off center, large											
Frequencies (Hz)	0.1						2					

Results



Data processing

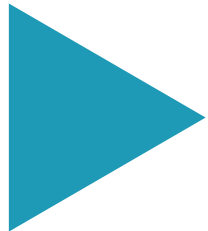
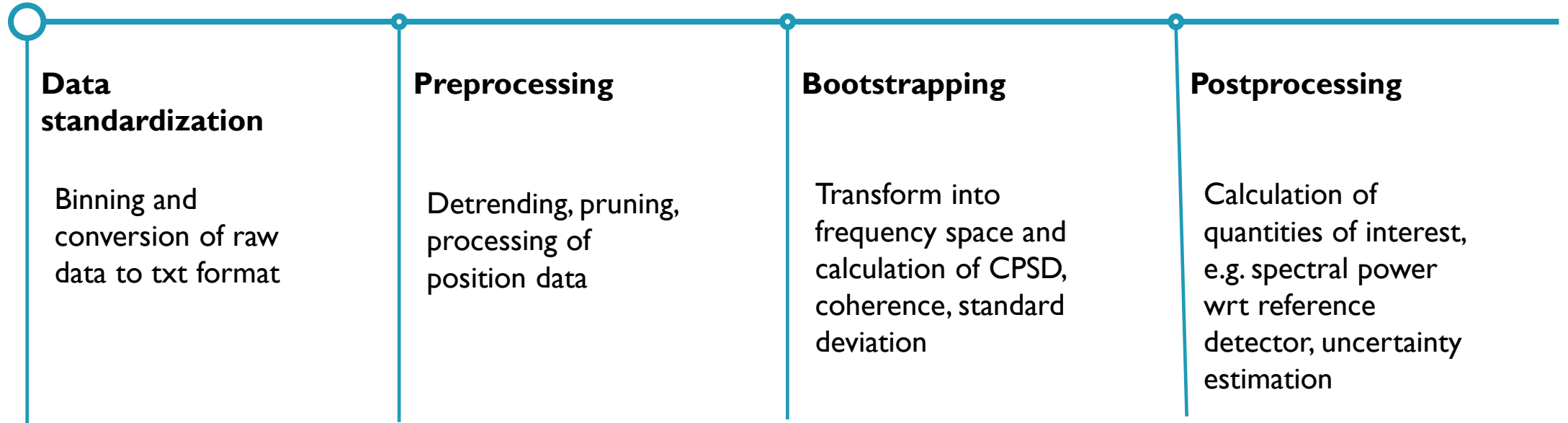

Quantities of interest

Spectral power wrt reference, phase of signal wrt reference, coherence **with** uncertainty estimation

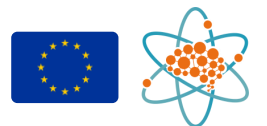

Location of detectors and noise sources during the second campaign

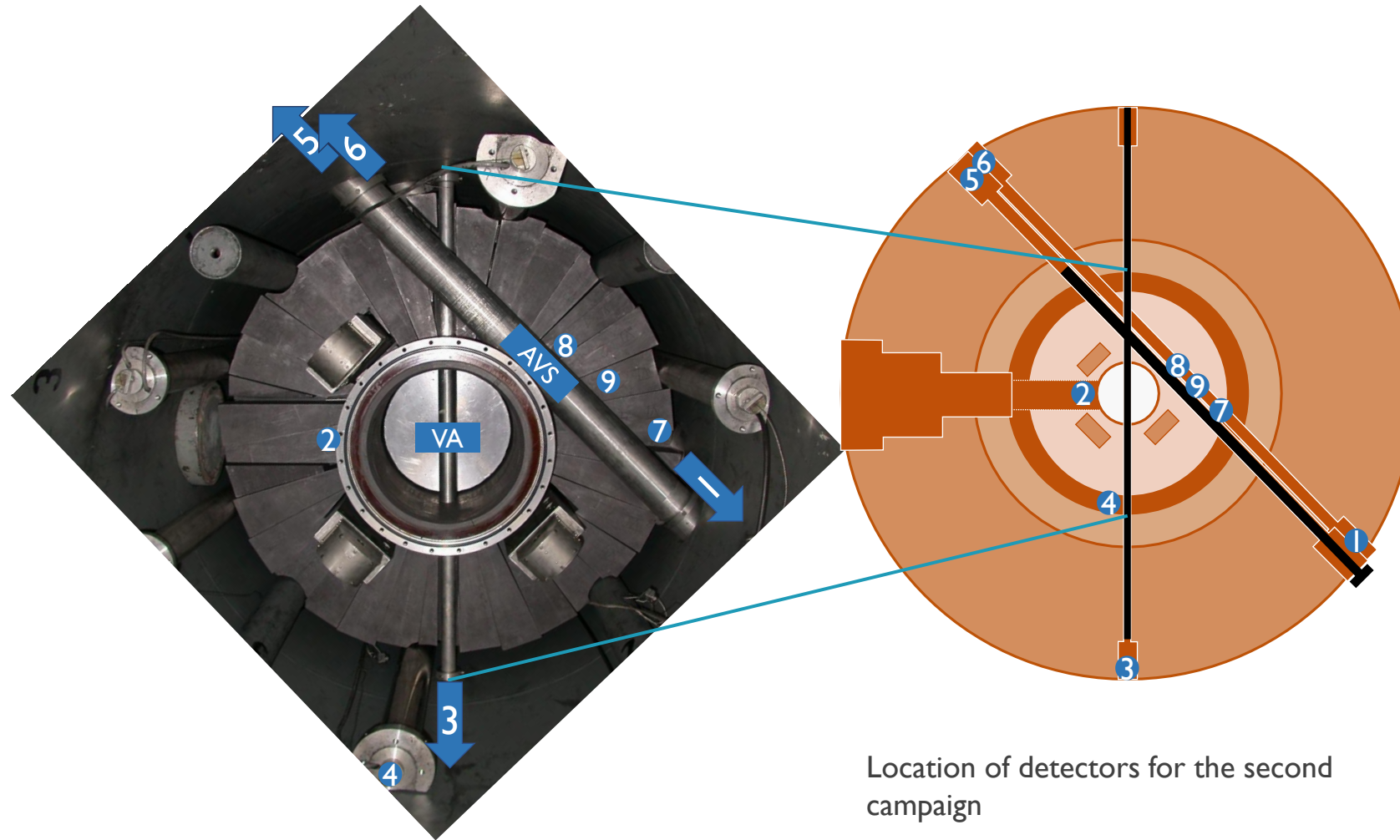

Location of detectors for the second campaign

Example of data analysis of AVS

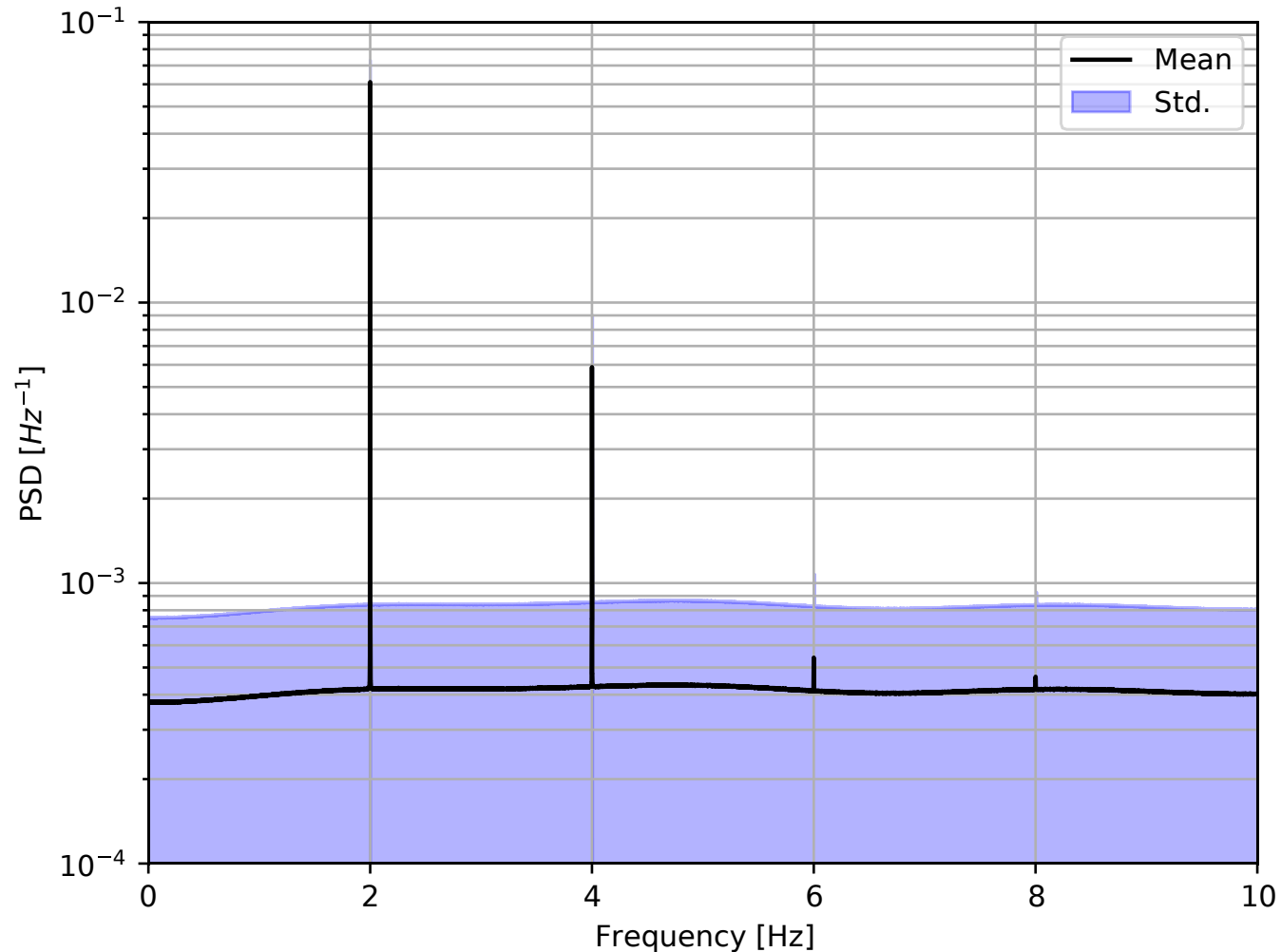

PSD of detector 1, Measurement 14, Second campaign, AVS, 2Hz, measurement time 2621.36 s, 300000 bootstraps

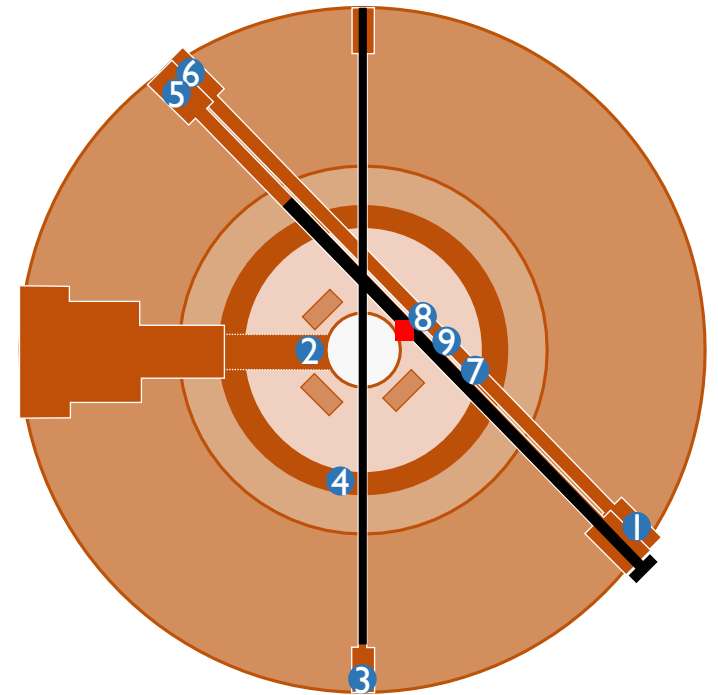

Location of detectors and location of AVS

Example of data analysis of AVS

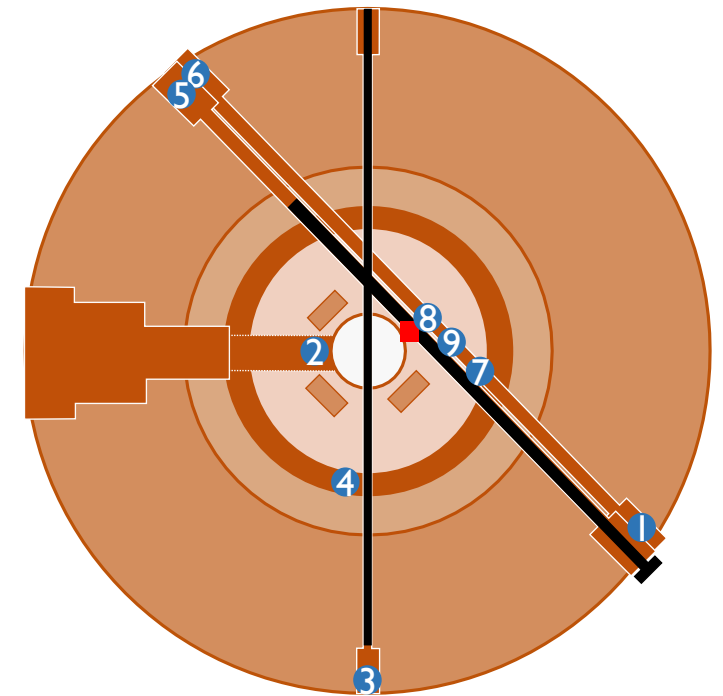
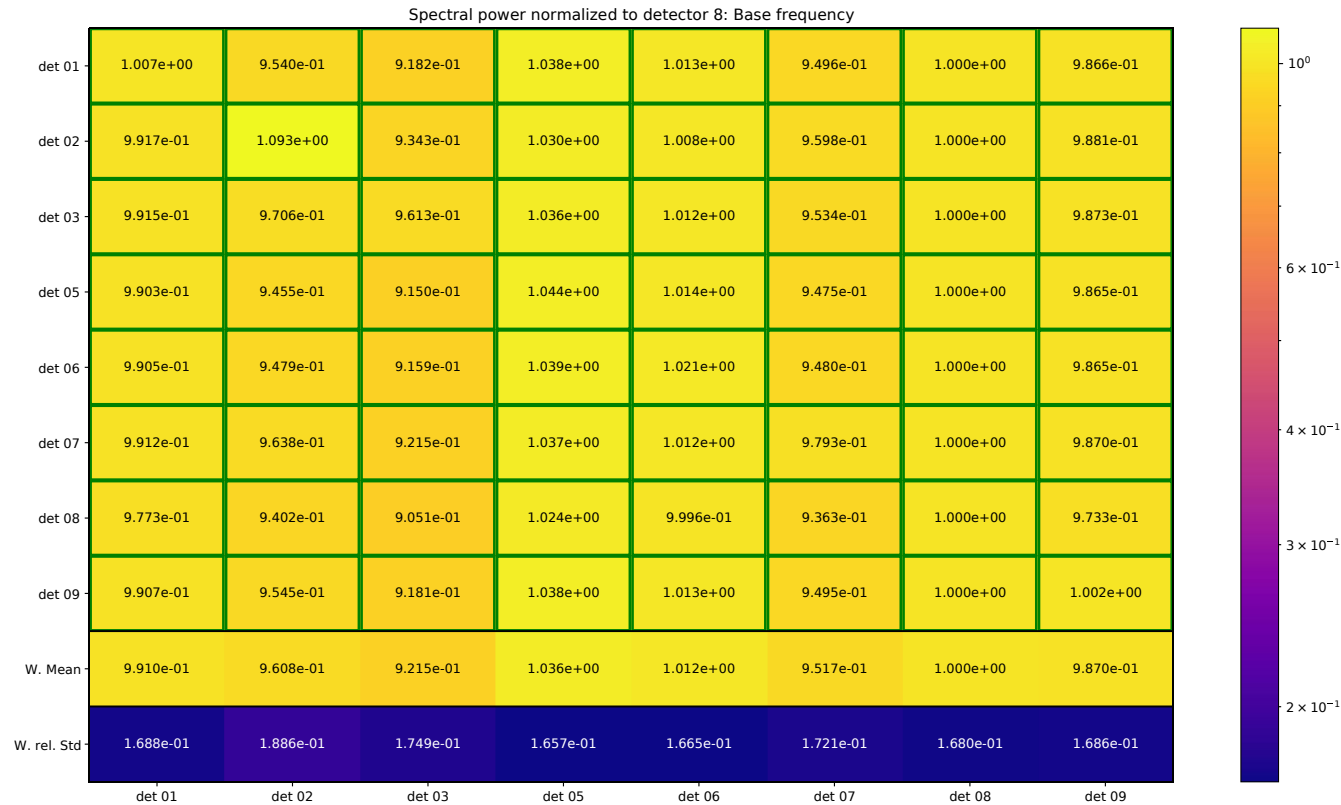

Spectral power wrt detector 08, Measurement 14, Second campaign, AVS, 2Hz, measurement time 2621.36 s, 300000 bootstraps

Location of detectors and location of AVS



Example of data analysis of AVS

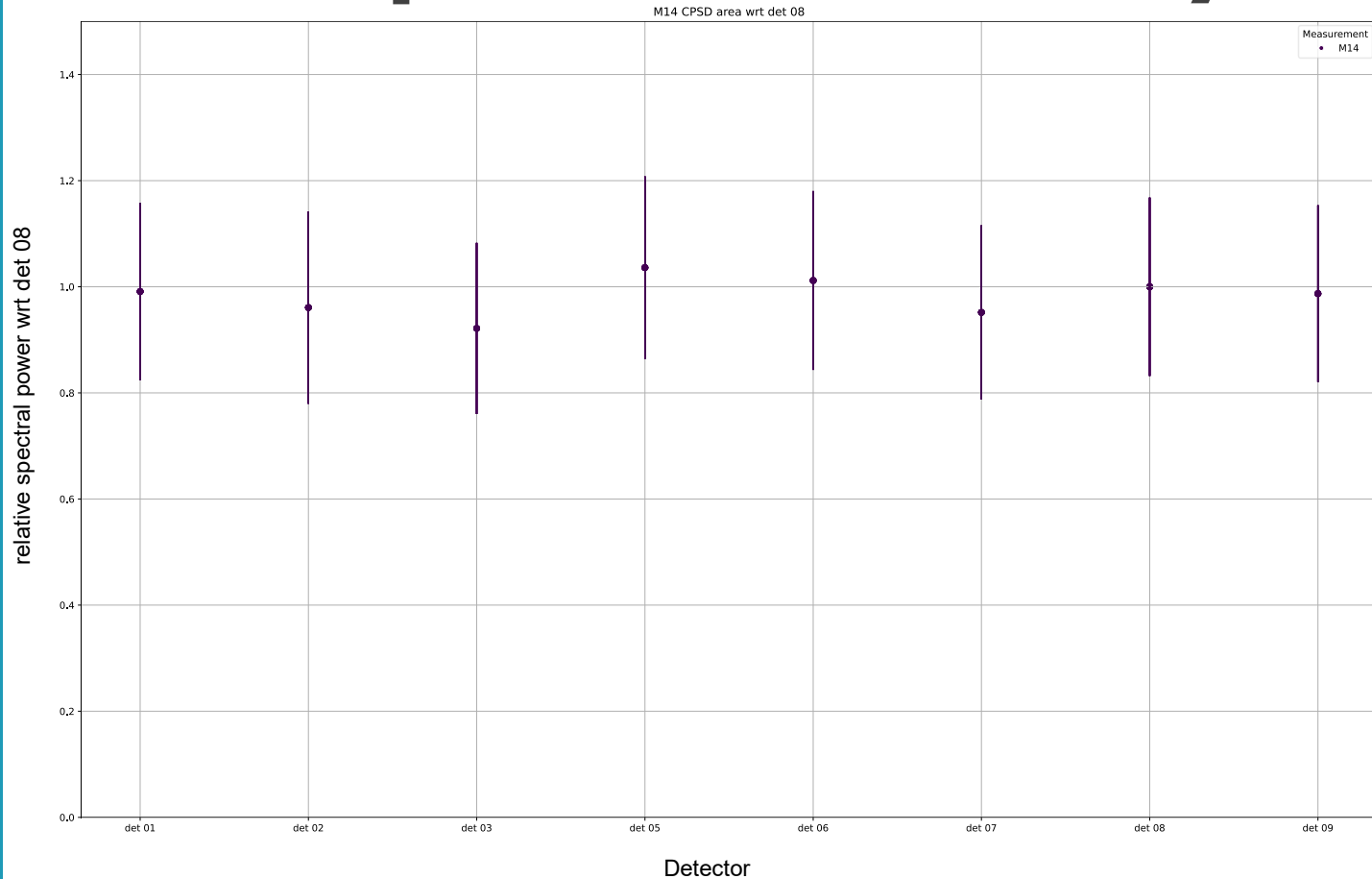

Relative spectral power wrt detector 08, Measurement 14, Second campaign, AVS, 2Hz, measurement time 2621.36 s, 300000 bootstraps

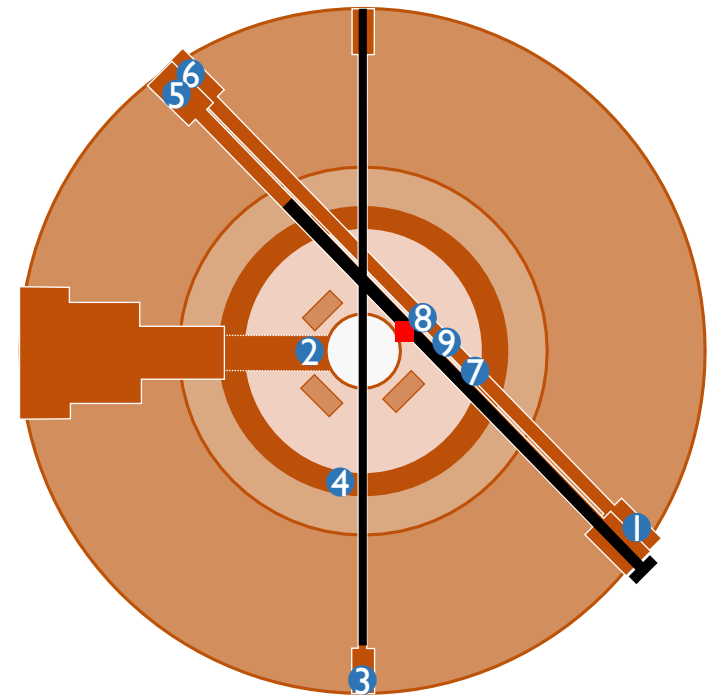

Location of detectors and location of AVS

Example of data analysis of AVS

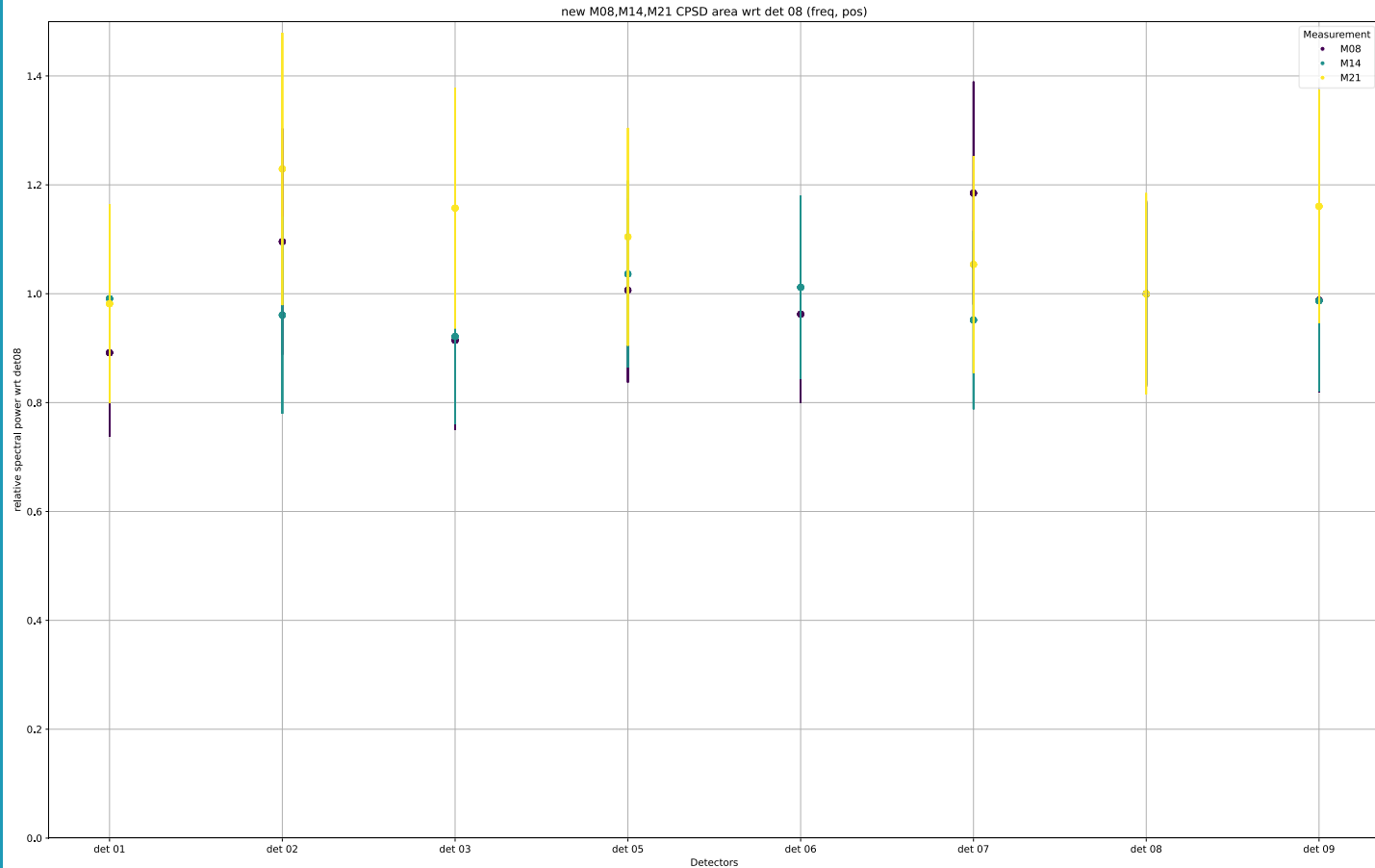

Relative spectral power wrt detector 08, comparison Measurement 08,14,21, Second campaign, AVS, 2Hz, 300000 bootstraps

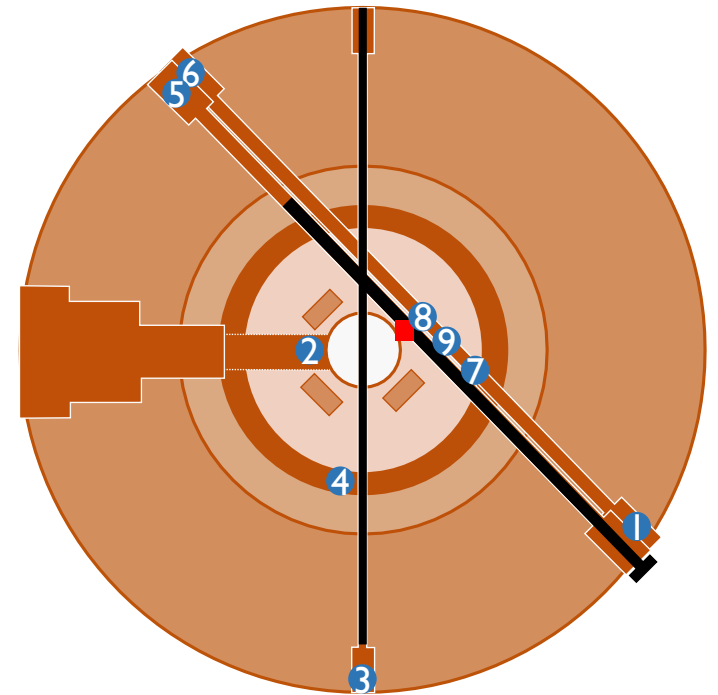

Location of detectors and location of AVS

Lessons learned

Validation experiments are not a simple task:

- 1 Different aims may have to be weighed against each other, e.g. small perturbation vs. high signal to noise
- 2 Measurements might have to be tailored to the data processing, e.g. a reliable position signal is needed for the bootstrapping
- 3 Quality and synchronicity of all signals has to be ensured to produce meaningful data

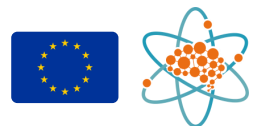

Thank you!



Backup



Example of data analysis of VA

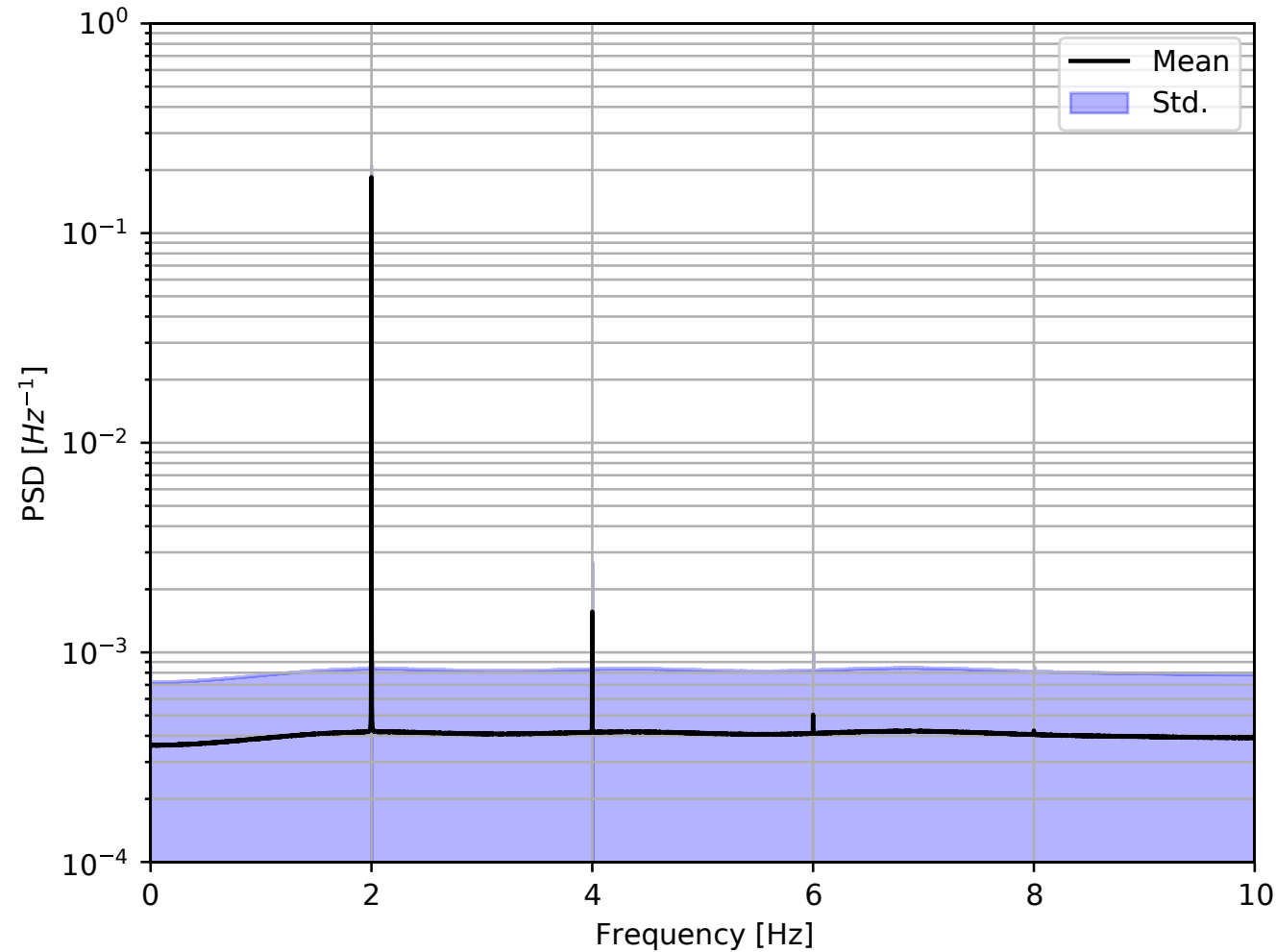

PSD of detector I, Measurement 20, Second campaign, VA, 2Hz, measurement time 1966.02 s, off-center, large amplitude, 300000 bootstraps

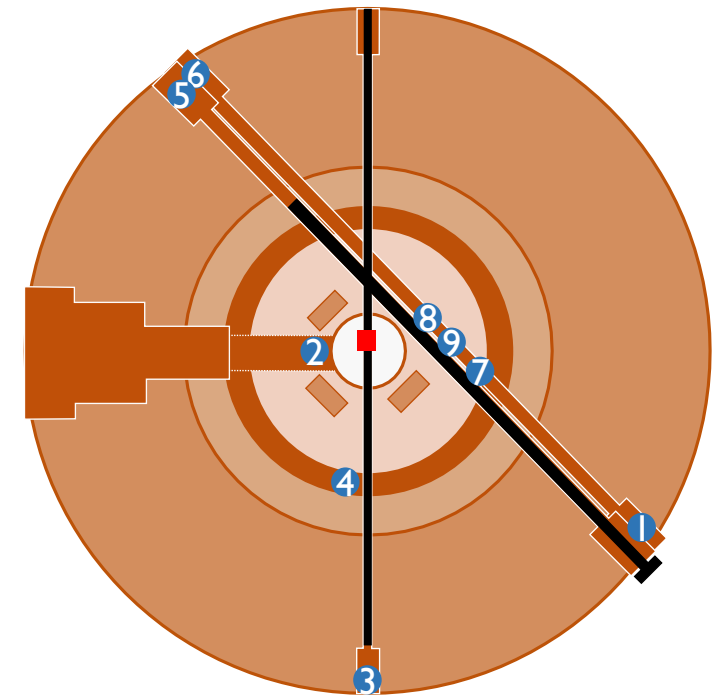

Location of detectors and location of VA

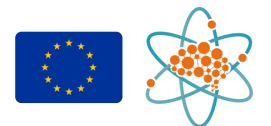

Example of data analysis of VA

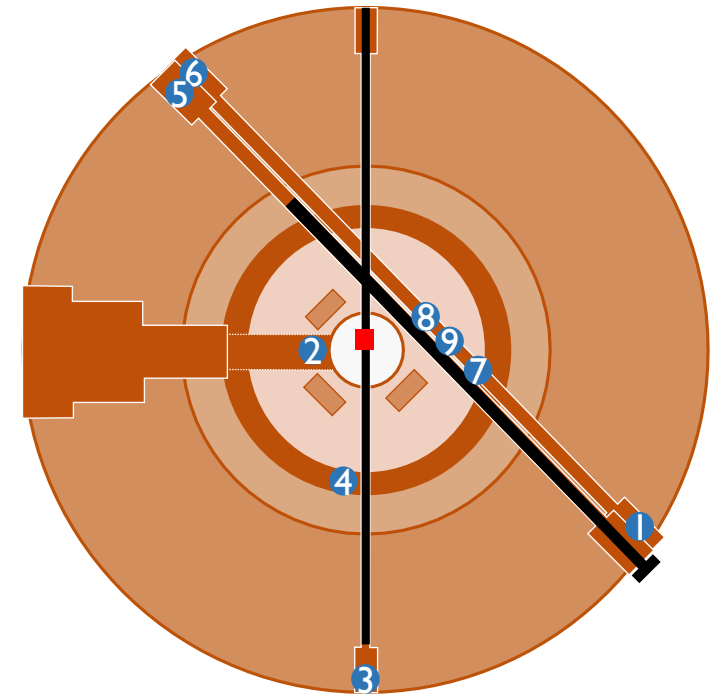

Relative spectral power wrt det 08, Measurement 20, Second campaign, VA, 2Hz, measurement time 1966.02 s, off-center, large amplitude, 300000 bootstraps

Location of detectors and location of VA

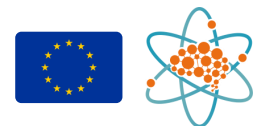

Example of data analysis of VA

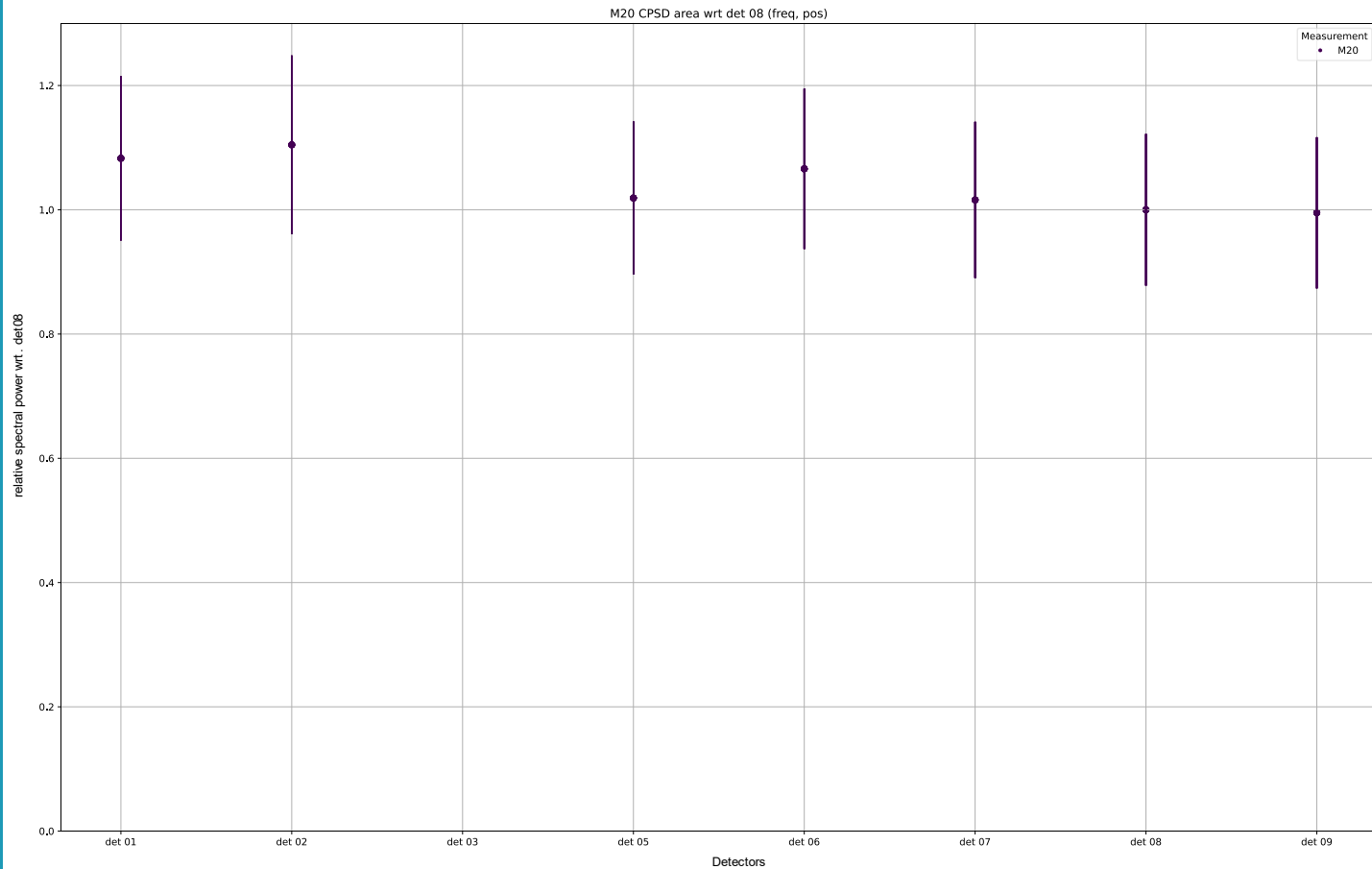

Relative spectral power wrt det 08, Measurement 20, Second campaign, VA, 2Hz, measurement time 1966.02 s, off-center, large amplitude, 300000 bootstraps

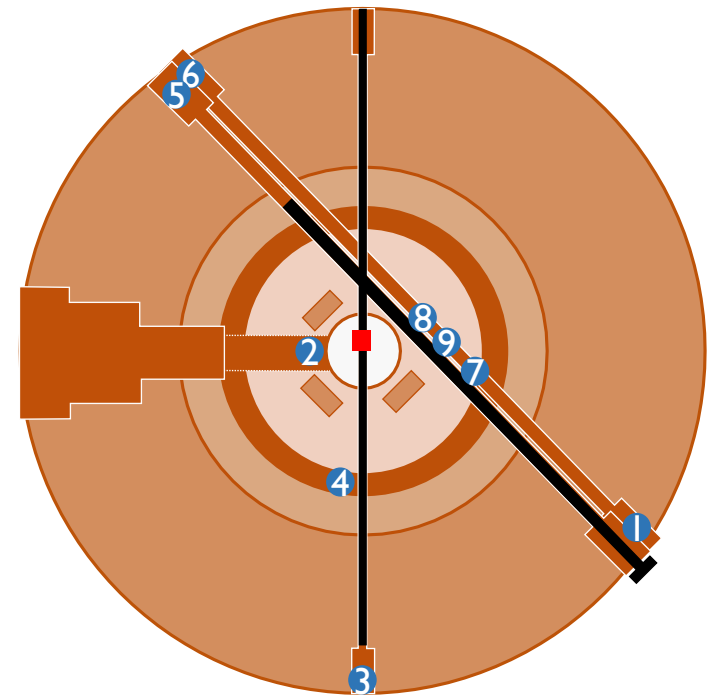

Location of detectors and location of VA



Evolution of DAQ

First campaign

- Also served as benchmark for EPFL and TUD DAQ against industry grade ISTec system
- ISTec Sigma (industry grade DAQ)
- EPFL Ortec multichannel scalers
- TUD Ortec multichannel scalers

Second campaign

- EPFL CAEN V2495 FPGA logical unit and PC communication board CAEN VI718
- TUD Zedboard with Zynq SoC FPGA board
- TUD Beaglebone minicomputer
- TUD Ortec multichannel scalers

Third campaign

- TUD Zedboard with Zynq SoC FPGA board
- TUD Beaglebone minicomputer

First campaign:

TUD
Ortec MCS

Benchmarks of DAQs

EPFL
Ortec MCS

ISTec
Sigma

Second campaign

Measurements with maximum number of detectors

TUD		
Ortec MCS	Beagle- bone	Zedboard FPGA

EPFL
CAEN FPGA

Third campaign

Maximum synchronization

TUD	
Beagle- bone	Zedboard FPGA



Evolution of AKR-2 experiments

- All aspects of the AKR-2 measurements were continuously improved over the course of the CORTEX project:

- 1 Detectors and detector setup
- 2 Noise sources
- 3 Data acquisition system
- 4 Parameters of measurements

